

PUMPER BODY

Long Aluminum 2nd Gen Pumper

CHASSIS

Enforcer Chassis

CHASSIS AXLE, FRONT, CUSTOM

19,500 Lb TAK-4 Axle

AXLE, REAR

27,000 Lb Meritor Axle

ENGINE

510 HP PACCAR MX13 Engine

TRANSMISSION

Allison 5th Gen, 4500 EVS P

BUMPER

19" Extended Painted Steel

CAB

7010 Enforcer Cab

BODY

WATER TANK

1000 Gallon Poly Water Tank

COMPT, PUMPER, REAR

30.75" FF RollUp Rear Compt

COMPT, PUMPER, LEFT SIDE

161" RollUp Full Height Front & Rear FDLR

COMPT, PUMPER, RIGHT SIDE

161" RollUp Full Height Front & Rear FDLR

FIRE SUPPRESSION PUMPHOUSE

52" Control Zone Side Mount

PUMP

1500 GPM Waterous CSU

CROSSLAYS, 1.50"

(2) 1.50" Standard Capacity

CROSSLAYS, 2.50"

(1) 2.50" Standard Capacity

SPEEDLAYS

Speedlays Not Required

GENERATOR

Generator Not Required

Foam System

Foam System Not Required

Foam Cell

Foam Cell Not Required

Side Roll and Frontal Impact Protection

NOTE

DIMENSIONS SHOWN ARE APPROXIMATE AND ARE SUBJECT TO MINOR DEVIATIONS AS MAY OCCUR OR BE NECESSARY IN CONSTRUCTION. MINOR DETAILS NOT SHOWN.

- ONE 1.50 OUTLET WITH 2.00 PIPING AND SWIVEL LOCATED IN CENTER BUMPER TRAY
- SHORELINE RECEPTACLE WITH KUSSMAUL SUPER AUTO-EJECT LOCATED ON DRIVER SIDE OF THE CAB
- AIR INLET WITH DISCONNECT COUPLING IN THE DRIVER SIDE STEPWELL
- BATTERY CHARGER LOCATED BEHIND DRIVER'S SEAT
- BATTERY CHARGE INDICATOR DISPLAYED THROUGH DRIVER SIDE WINDOW
- SIX ADJUSTABLE SHELVES IN COMPARTMENTS PER SHOP ORDER
- FOUR FLOOR MOUNTED SLIDE-OUT TRAYS LOCATED PER SHOP ORDER

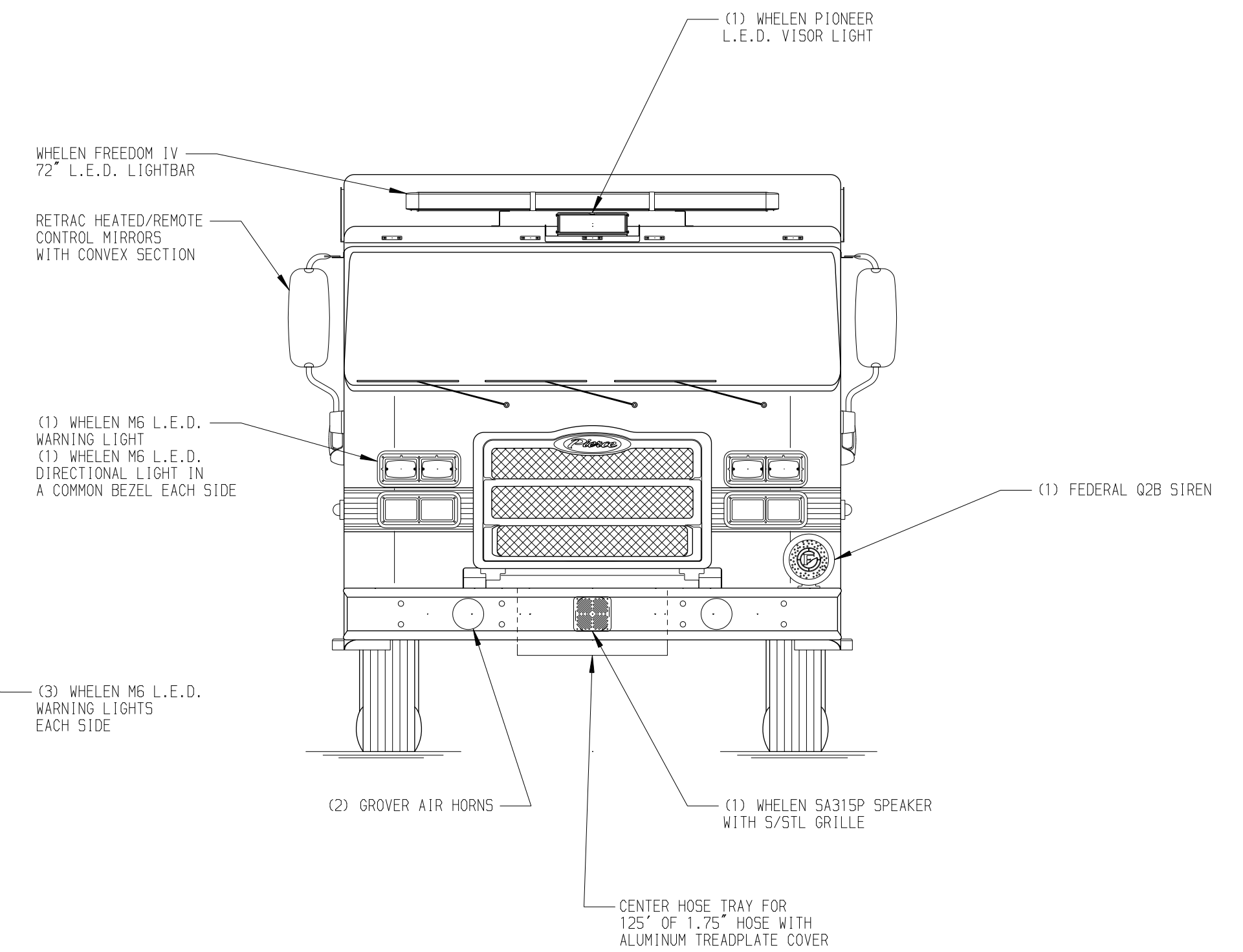
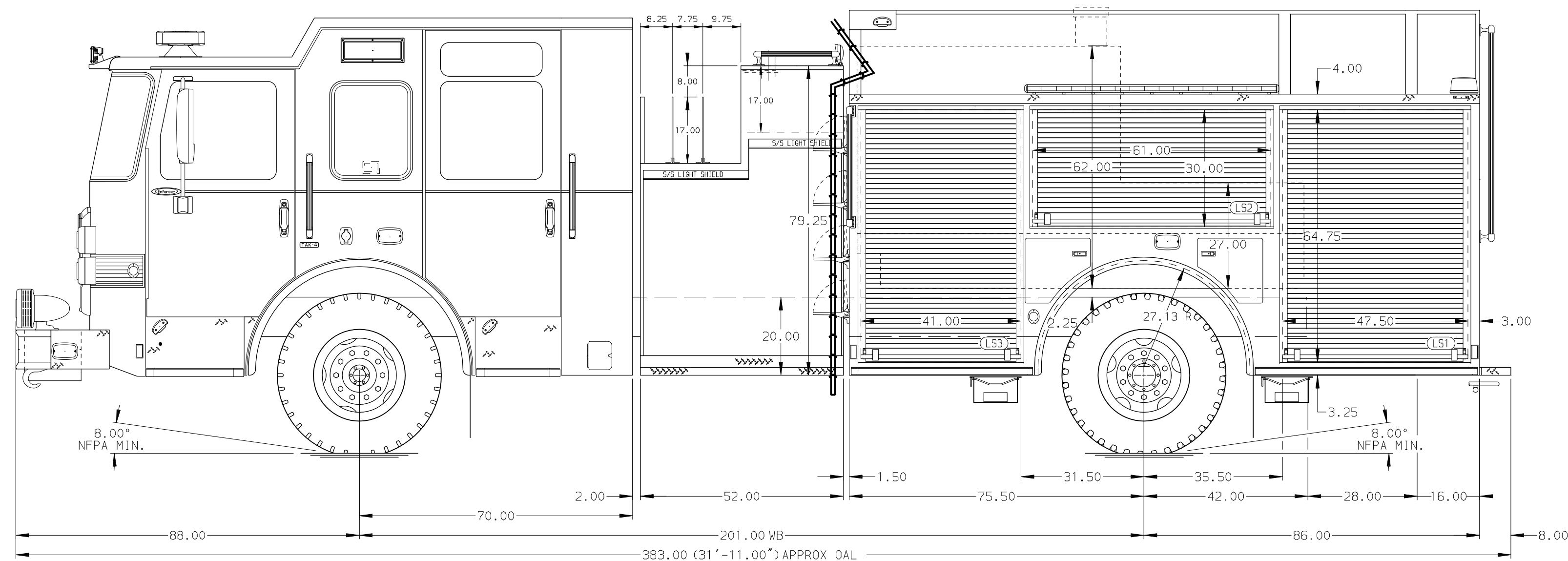
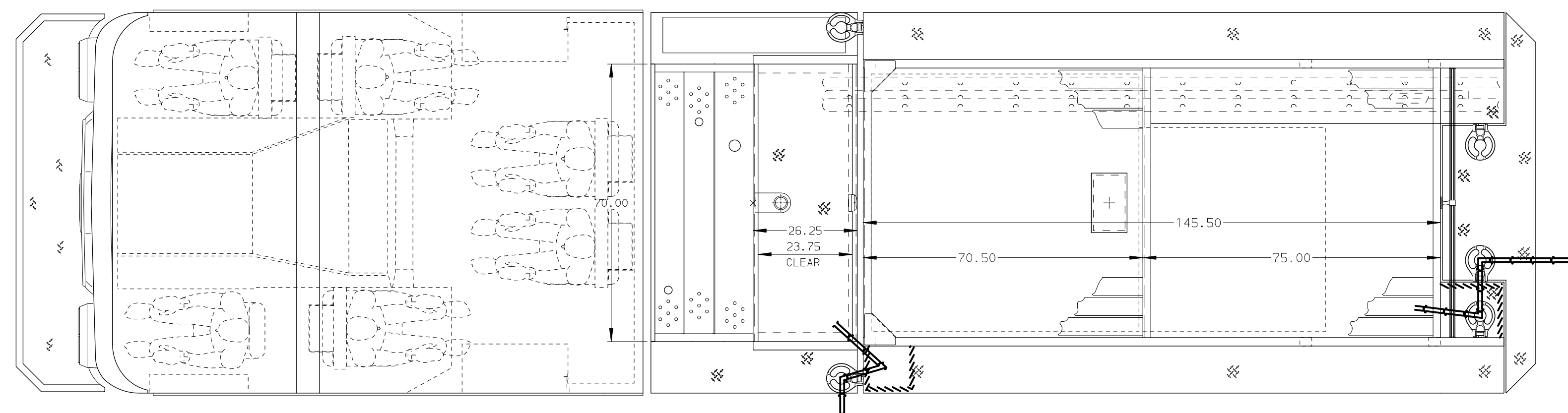
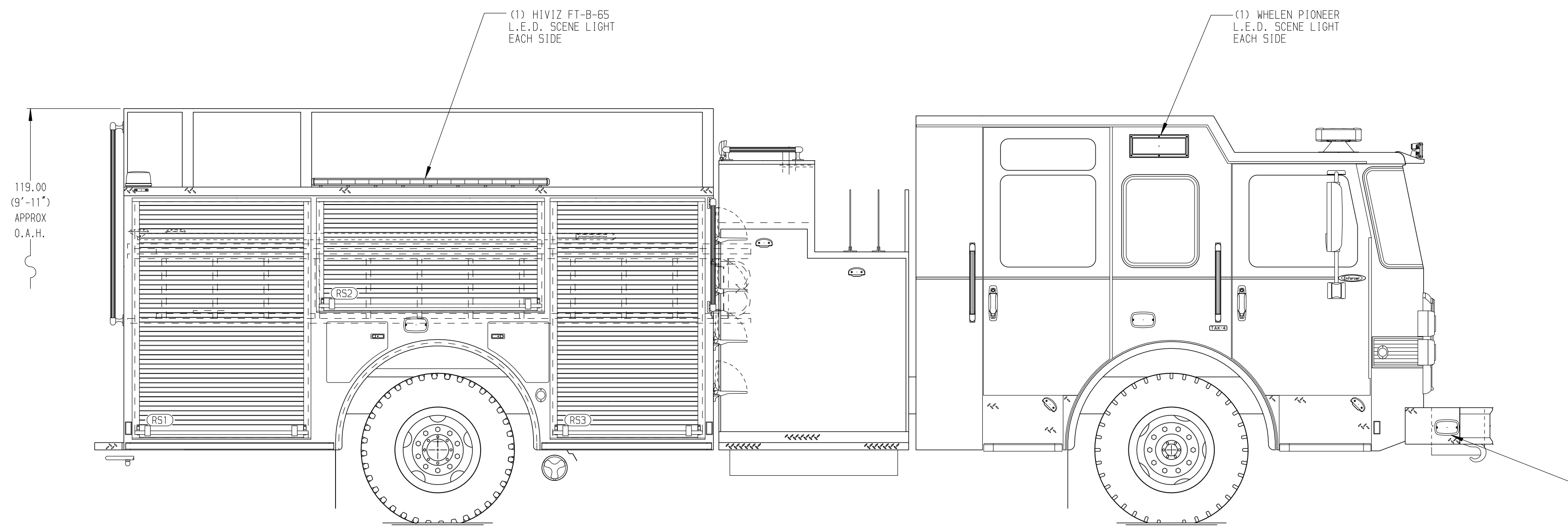

HOSEBED CAPACITY	
BED 1	300' OF 3.00" D.J. POLY HOSE
BED 2	1000' OF 5.00" D.J. POLY HOSE
BED 3	250' OF 3.00" D.J. POLY HOSE

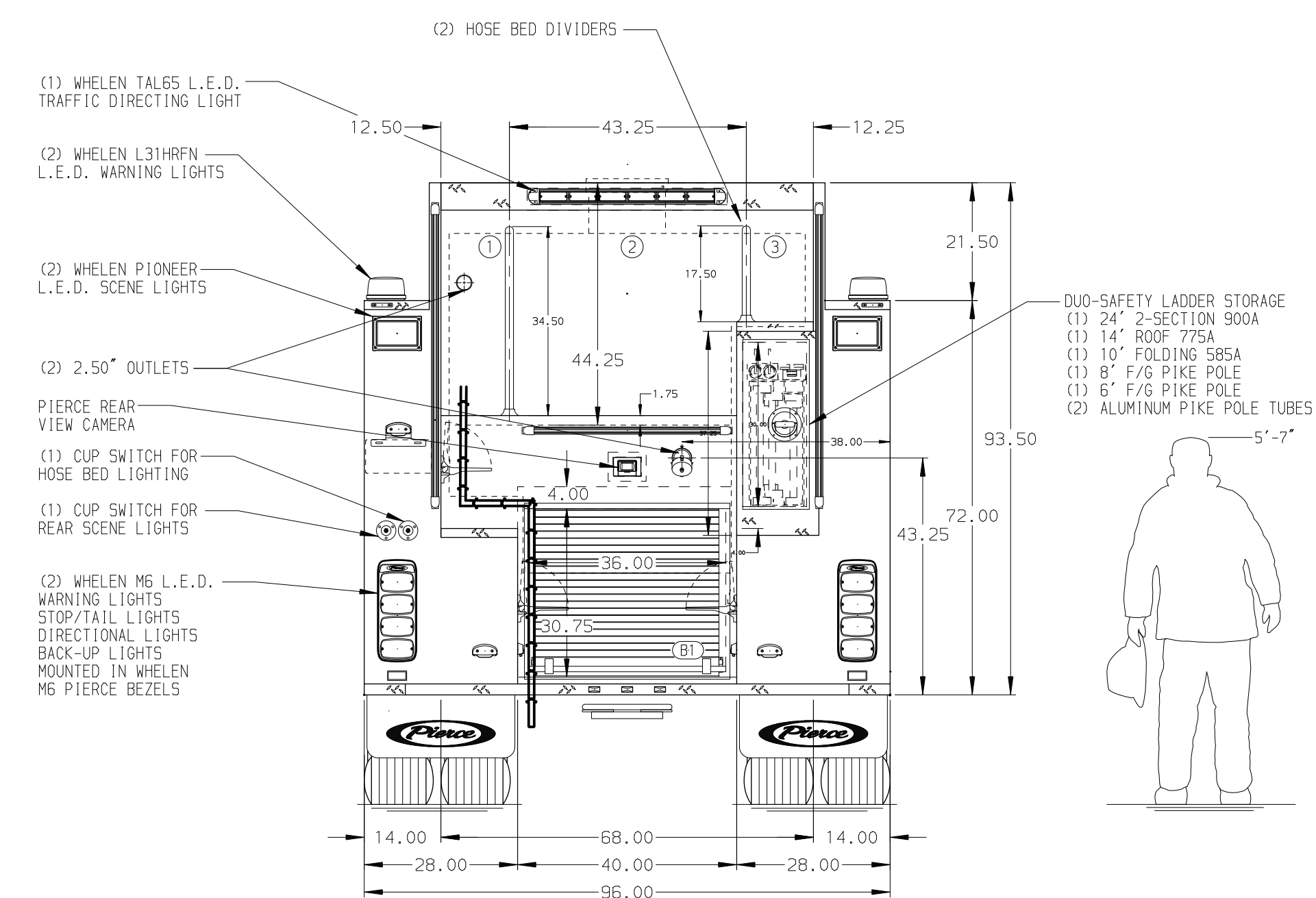

CUSTOMER APPROVAL

APPROVED BY: _____
DATE: _____



REV	DATE	BY	CH	ENFORCER

TITLE	FOR	DWG NO.
Pierce Pumper Approval Drawing	Pierce Field Unit	37192AD

JOB NO.	37192
SCALE	1:24
DATE	
DRAWN BY	COL
CHECKED BY	THS
SHEET SIZE	D
SHEET NO.	1 OF 1